

HEAD PRESSURE CONTROL VALVES

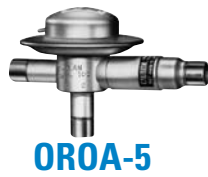

Listed by Underwriters' Laboratories, Inc. Guide SFJQ2 File No. SA5460



LAC-10



High and Low Ambient Stability

The design of air conditioning systems utilizing air cooled condensing units involves two main problems that must be solved if the system is to operate reliably and economically...**high ambient** and **low ambient** operation. If the condensing unit is properly sized, it will operate satisfactorily during extremely high ambient temperatures. However, some units will be required to operate at ambient temperatures below their design dry bulb temperature during most of the year, the solution to low ambient operation is more complex.

Without good head pressure control during low ambient operation, the system can experience both running cycle and off-cycle problems. Since the pressure differential across the thermostatic expansion valve port affects the rate of refrigerant flow, low head pressure generally causes insufficient refrigerant to be fed to the evaporator. Failure to have sufficient head pressure will result in low suction pressure and/or iced evaporator coils.

The primary off-cycle problem is refrigerant migration to the condenser. Insufficient flow through the TEV will cause a low suction pressure.

The typical method of maintaining normal head pressure in a refrigeration system during periods of low ambient temperature is to restrict liquid flow from the condenser to the receiver, and at the same time divert hot gas to the inlet of the receiver. This backs liquid refrigerant up into the condenser reducing its capacity which in turn increases the condensing pressure. At the same time the hot gas raises liquid pressure in the receiver, allowing the system to operate normally.

Sporlan Head Pressure Control for systems with air cooled condensers can be accomplished using one of several valve options; the non-adjustable OROA-5, the adjustable ORI/ORD combination, or the economical LAC series.

Specifications and Dimensions

VALVE TYPE	STANDARD FACTORY SETTING bar	CONNECTIONS ODF SOLDER (Inches)		DIMENSIONS – mm								WEIGHT kg		REPLACEMENT PARTS		
		INLET(S)	OUTLET	A	B	C	D	E	F	G	I	NET	SHIP			
ORI-6-65/225-H	8.3	5/8	5/8	250	128	162	—	—	—	—	—	—	.45	.57	Inlet Strainer	825-5
		7/8	7/8													825-7
		1-1/8	1-1/8													825-9
ORI-10-65/225-H	8.3	1-1/8	1-1/8	280	139	167	—	—	—	—	—	1.13	1.25	825-9		
		1-3/8	1-3/8											825-11		
ORD-4-20	1.4	5/8	5/8	167	25	—	—	—	—	—	—	.15	.23	825-5		
OROA-5	6.9, 12.4 or 14.5	⊕ 5/8	5/8	151	95	48	55	—	—	—	—	.91	1.02	825-5		
		⊕ 5/8	7/8	157	102	54	61							825-7		

① Discharge Connection ② Condenser Connection

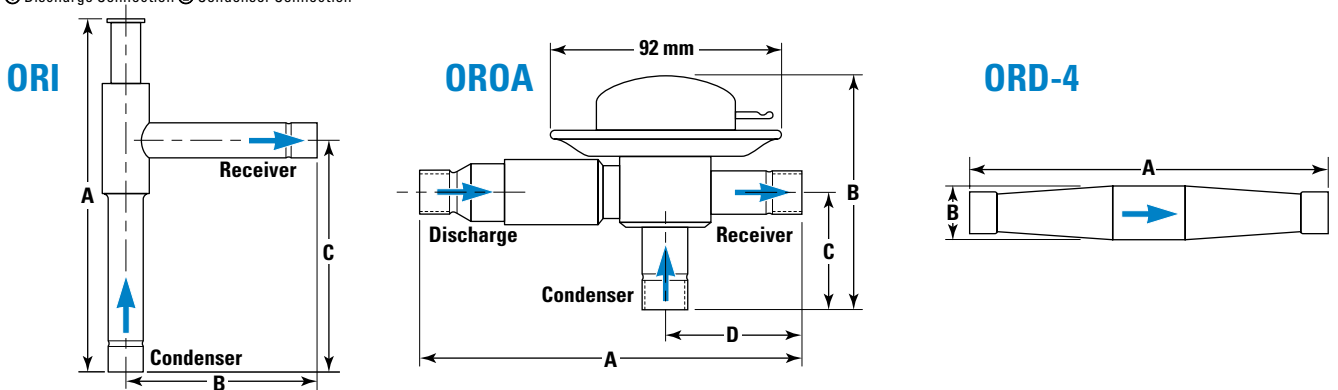

ORI – Valve Nomenclature/Ordering Instructions

ORI	6	65/225	7/8" ODF	With Strainer	H
Valve Type: Open on Rise of Inlet Pressure	Port Size Eighths of an Inch	Nominal Adjustment Range (psig)	Connections - Solder	Inlet Strainer (Optional)	Designates High Pressure Bellows

OROA – Valve Nomenclature/Ordering Instructions

OROA	5	180	5/8" ODF	With Strainer
Valve Type: Open on Rise of Outlet Pressure	Port Size Eighths of an Inch	Pressure Setting (psig)	Connections - Solder	Inlet Strainer (Optional)

ORD-4

ORD	4	20
Valve Type: Open on Rise of Differential Pressure	Port Size Eighths of an Inch	Opening Pressure Differential (psi)

HEAD PRESSURE CONTROL VALVES

Specifications and Dimensions

VALVE TYPE	STANDARD FACTORY SETTING bar	CONNECTIONS ODF SOLDER (Inches)		DIMENSIONS – mm								WEIGHT kg		REPLACEMENT PARTS	
		INLET(S)	OUTLET	A	B	C	D	E		F	G	I	NET		SHIP
LAC-4	6.9, 12.4 or 14.5	1/4	1/4	45	48	77	61	120					.34	.39	Replacement Elements Not Available
		3/8	3/8										.36	.40	
LAC-4-DS		1/2	1/2	45	48	77	61	155					.37	.41	
		3/8	3/8										.40	.46	
LAC-5		1/2	1/2	42	41	96	76	D3L	R3L	155	142	1.13	1.20	Non-Adjustable Dome Element: D3L (specify setting) or Non-Adjustable Remote Bulb Element: R3L (specify setting)	
		5/8	5/8	44	43	98	78			157	144	1.16	1.22		
		7/8	7/8	57	55	110	91			170	157	1.18	1.25		
		1-1/8	1-1/8	61	60	114	95			173	161	1.25	1.32		
LAC-10		Ⓞ 1-3/8 Ⓜ 7/8	7/8	72	68	112	88	D3L	R3L	176	163	1.45	1.55		
		Ⓞ 1-3/8 Ⓜ 1-1/8	1-1/8		65	123	98			187	174	1.49	1.59		

Ⓞ Discharge Connection
Ⓜ Condenser Connection

LAC-4

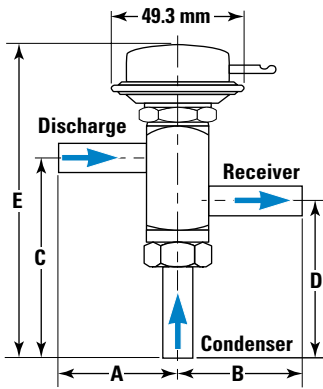

LAC-4-DS

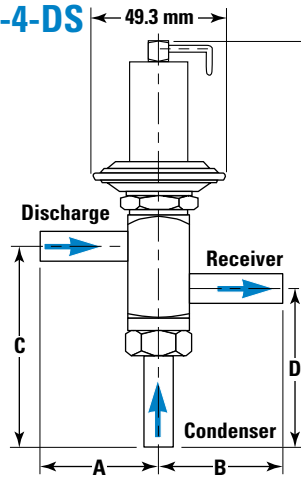

LAC-5 & 10

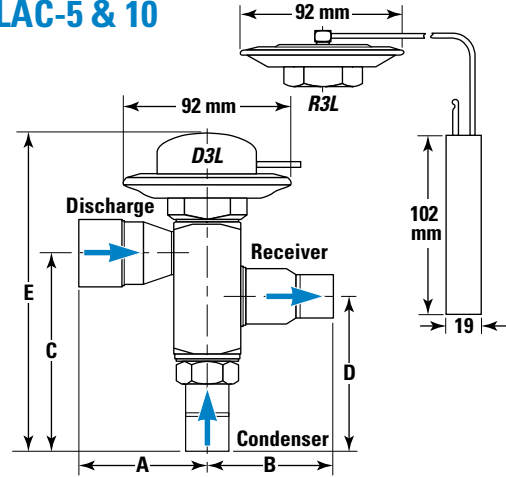

LAC – Valve Nomenclature/Ordering Instructions

To eliminate shipment delays, specify complete valve designations.

LAC	4	DS	100/180	3/8"	X	3/8"	X	3/8	ODF
Valve Type: Low Ambient Control	Valve Size	Dual Setting Omit for standard dome element	Valve Setting(s) (psig) Specify one setting for standard dome element	Discharge Connection (Inches)		Condenser Connection (Inches)		Receiver Connection (Inches)	Solder Connections
LAC	5	180	R	5/8"	X	5/8"	X	3/8	ODF
Valve Type: Low Ambient Control	Valve Size	Valve Setting(s) (psig)	Indicates Remote Bulb Model Delete for standard dome element	Discharge Connection (Inches)		Condenser Connection (Inches)		Receiver Connection (Inches)	Solder Connections

HEAD PRESSURE CONTROL VALVES

Low Ambient (WINTER) Capacities – kW of Refrigeration

Capacities are based on -20°C evaporator temperature, 35°C condenser, 6°C subcooled liquid.

REFRIGERANT Valve Setting (bar)	MINIMUM AMBIENT DESIGN TEMP. °C	PRESSURE DROP ACROSS VALVE (bar)	VALVE TYPE					REFRIGERANT Valve Setting (bar)	MINIMUM AMBIENT DESIGN TEMP. °C	PRESSURE DROP ACROSS VALVE (bar)	VALVE TYPE				
			LAC-4	LAC-5	LAC-10	OROA-5	ORD-4				LAC-4	LAC-5	LAC-10	OROA-5	ORD-4
22 407C (12.4 bar)	-30	0.07	5.96	10.6	25.4	—	—	404A (14.5 bar)	-30	0.07	4.37	7.75	18.7	—	—
		0.14	8.38	14.9	35.7	—	—			0.14	6.15	11.0	26.2	—	—
		0.35	13.1	23.6	55.5	—	—			0.35	9.63	17.3	40.9	—	—
		1.60	26.9	49.6	112	54.4	54.4			1.60	19.9	36.5	83.0	39.5	39.5
	-20	2.00	29.8	55.2	123	83.3	83.3		2.00	22.0	40.6	91.5	60.4	60.4	
		0.07	6.38	11.3	27.1	—	—		0.07	4.64	8.20	19.7	—	—	
		0.14	8.97	16.0	38.0	—	—		0.14	9.52	11.6	27.7	—	—	
		0.35	14.0	25.2	59.1	—	—		0.35	10.2	18.3	43.1	—	—	
	-10	1.60	28.8	53.0	119	61.3	61.3		1.60	21.1	38.6	87.4	44.0	44.0	
		2.00	31.8	59.0	131	93.8	93.8		2.00	23.3	43.0	96.3	67.4	67.4	
		0.07	6.91	12.2	29.2	—	—		0.07	4.98	8.78	21.1	—	—	
		0.14	9.71	17.2	40.8	—	—		0.14	7.00	12.4	29.5	—	—	
134a (6.9 bar)	-30	0.35	15.2	27.2	63.5	—	—	507 (14.5 bar)	-30	0.35	10.9	19.6	45.9	—	—
		1.60	31.1	57.2	127	71.2	71.2			1.60	22.5	41.3	92.9	50.7	50.7
		2.00	34.3	63.7	140	109	109			2.00	24.9	46.0	102	77.6	77.6
		0.07	4.86	8.65	20.9	—	—			0.07	4.12	7.32	17.6	—	—
	-20	0.14	6.83	12.2	29.2	—	—		0.14	5.80	10.3	24.8	—	—	
		0.35	10.7	19.2	45.4	—	—		0.35	9.10	16.3	38.6	—	—	
		1.60	21.4	40.1	88.8	40.6	40.6		1.60	18.8	34.5	78.5	37.2	37.2	
		2.00	23.5	44.5	96.6	62.4	62.4		2.00	20.8	38.4	86.5	57.0	57.0	
	-10	0.07	5.24	9.3	22.4	—	—		0.07	4.40	7.79	18.7	—	—	
		0.14	7.36	13.1	31.3	—	—		0.14	6.20	11.0	26.3	—	—	
		0.35	11.5	20.7	48.5	—	—		0.35	9.70	17.4	40.9	—	—	
		1.60	23.1	43.1	94.9	45.7	45.7		1.60	20.0	36.7	83.0	41.9	41.9	
R-410A (20.3 bar)	-30	2.00	25.3	47.8	103	70.2	70.2	2.00	22.1	40.9	91.5	64.1	64.1		
		0.07	5.73	10.1	24.3	—	—	0.07	4.75	8.38	20.1	—	—		
		0.14	8.05	14.3	34.0	—	—	0.14	6.68	11.8	28.1	—	—		
		0.35	12.5	22.6	52.7	—	—	0.35	10.4	18.7	43.8	—	—		
	-20	1.60	25.2	47.1	103	53.3	53.3	1.60	21.5	39.5	88.6	48.7	48.7		
		2.00	27.6	52.2	112	81.8	81.8	2.00	23.8	43.9	97.6	74.6	74.6		
		0.07	6.06	10.8	20.3	—	—	0.07	4.75	8.38	20.1	—	—		
		0.14	8.54	15.2	28.5	—	—	0.14	6.68	11.8	28.1	—	—		
	-10	0.35	13.4	24.0	44.4	—	—	0.35	10.4	18.7	43.8	—	—		
		0.70	18.8	33.9	61.8	—	—	1.60	21.5	39.5	88.6	48.7	48.7		
		0.07	6.48	11.5	21.6	—	—	2.00	23.8	43.9	97.6	74.6	74.6		
		0.14	9.13	16.2	30.3	—	—								
-20	0.35	14.3	25.6	47.2	—	—									
	0.70	20.0	36.1	65.6	—	—									
	0.07	7.0	12.4	23.2	—	—									
	0.14	9.85	17.5	32.5	—	—									
-10	0.35	15.4	27.6	50.6	—	—									
	0.70	21.6	38.9	70.4	—	—									

High Ambient (SUMMER) Capacities – kW of Refrigeration

Capacities are based on -20°C evaporator temperature, 43°C condenser, 6°C subcooled liquid.

REFRIGERANT	PRESSURE DROP ACROSS VALVE (bar)	VALVE TYPE						REFRIGERANT	PRESSURE DROP ACROSS VALVE (bar)	VALVE TYPE							
		LAC-4	LAC-5	LAC-10	OROA-5	ORI-6	ORI-10			ORD-4	LAC-4	LAC-5	LAC-10	OROA-5	ORI-6	ORI-10	ORD-4
22 407C	0.07	9.13	19.5	41.5	37.0	26.0	69.2	—	404A	0.07	5.71	12.2	26.0	23.0	17.5	48.4	—
	0.14	12.8	27.6	57.7	52.1	37.8	95.6	—		0.14	7.98	17.2	36.1	32.5	25.4	66.8	—
	0.21	15.5	33.9	69.9	63.7	47.0	116	—		0.21	9.70	21.1	43.8	39.7	31.7	80.7	—
	0.28	17.8	39.1	80.1	73.5	54.9	132	—		0.28	11.2	24.4	50.2	45.8	37.0	92.3	—
	0.35	19.9	43.7	89.0	82.1	61.9	147	—		0.35	12.4	27.2	55.8	51.2	41.7	102	—
134a	0.07	8.15	17.4	37.1	33.0	18.2	45.6	—	507	0.07	5.58	11.9	25.5	22.6	17.8	49.3	—
	0.14	11.4	27.4	51.5	46.5	26.4	63.0	—		0.14	7.80	16.9	35.3	31.8	25.8	68.1	—
	0.21	13.9	30.2	62.4	56.9	32.9	76.1	—		0.21	9.49	20.7	42.8	38.9	32.1	82.3	—
	0.28	15.9	34.9	71.5	65.6	38.5	87.0	—		0.28	10.9	23.9	49.1	44.9	37.5	94.1	—
410A	0.35	17.7	39.0	79.5	73.2	43.4	96.5	—	0.35	12.2	26.7	54.5	50.1	42.4	104	—	
	0.07	8.70	18.6	29.3	—	—	—	—									
	0.14	12.2	26.3	40.7	—	—	—	—									
	0.21	14.8	32.2	49.3	—	—	—	—									
	0.28	17.0	37.2	56.5	—	—	—	—									
0.35	18.9	41.6	62.8	—	—	—	—										